



Premium Quality Vacuum Pump Oil

A specially blended premium quality vacuum pump oil suitable for all makes of vacuum pumps. Designed to give the maximum protection against wear and corrosion giving extended pump life and improved efficiency.

- Inhibits oxidation
- Anti-foaming
- Protects against corrosion
- Excellent anti-wear properties

DESCRIPTION	SIZE	PART NUMBER
Premium quality vacuum pump oil	5 Litre	VPO005
	20 Litre	VPO020



Mechanical Slurry Pump MEC/M Series

SPECIFICATIONS

	MEC8000M
Max flow rate	8100 lpm
Max RPM	600rpm
Max absolute pressure	2.5 bar
Max relative pressure	1.5 bar
Vacuum with depression valve fitted	-0.80 bar
Max vacuum	-0.94 bar
Power absorption at 1.5 bar absolute, 540rpm	15 kW
Power absorption at 1.5 bar relative, 540rpm	24 kW
Power absorption at 1.5 bar absolute, 1000rpm	9.5 kW
Power absorption at 1.5 bar relative, 1000rpm	21 kW
Splined shaft EN ISO 500 Ø	1 3/8"
Valve hole	1 1/2" BSP
Nett weight	160 Kg

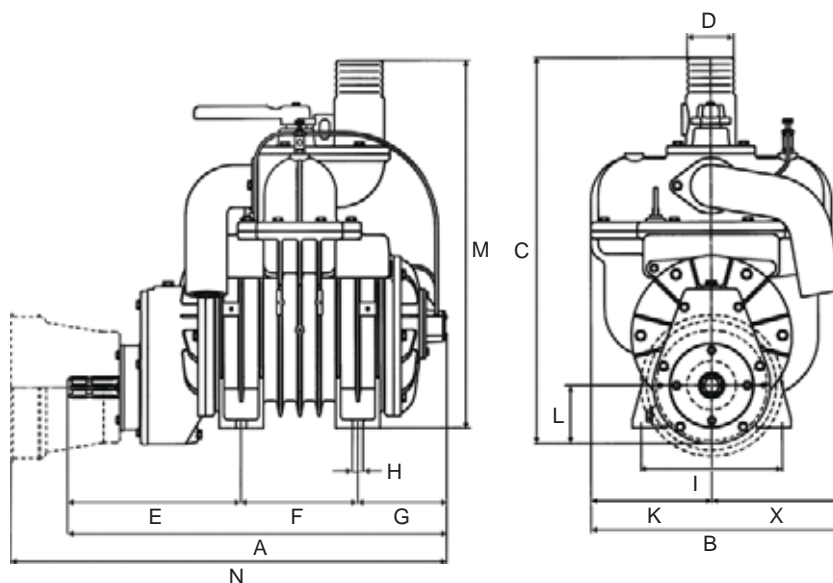

DESCRIPTION	A	B	C	D	E	F	G	H	I	L	M	N	K	X	PART NUMBER
8000 litre Mechanical MEC Pump	761	410	623	80	313	252	196	15	227	95	597	813	195	215	MEC8000M



Hydraulic Driven Slurry Pump - MEC Series

Please contact our Sales Staff for further details.

DESCRIPTION	PART NUMBER
8000 litre Hydraulic driven vacuum pump c/w motor	MEC8000HC/WMOTOR
Replacement motor to suit (c/w ports & gears)	KM35.51S