

Group 2 Gear Pump

DISPLACEMENT cm ³ /rev	MAX WORKING PRESSURE bar			MAX SPEED rpm	MAX FLOW lpm	INLET PORT mm	OUTLET PORT mm	DIMENSIONS		RIGHT HAND
	P1	P2	P3					A	B	
11	250	270	290	3500	38.5	30	30	50.2	104.6	2SPA11D
16.5	230	240	250	3500	57.7	40	30	54.8	113.8	2SPA16D
26	170	180	190	2500	65	40	30	62.7	129.6	2SPA26D

Note: Contact our Sales Staff if you are unable to find any of your requirements here as it is possible to acquire different variations of pump.

P1 = Continuous Pressure
 P2 = Max Intermediate Pressure
 P3 = Max Peak Pressure

Group 2 Gear pumps to suit KOMATSU Mini Excavator, KUBOTA Mini Excavator and PERKINS are available on request. Contact our Sales Staff with your enquiry.

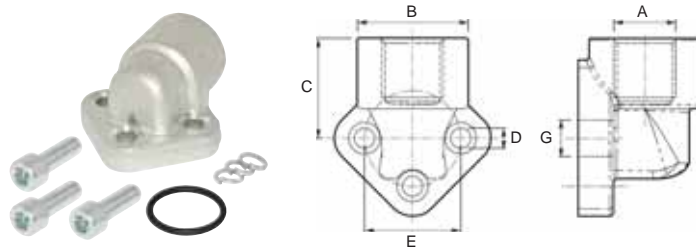

Group 2 Gear Pump Elbow Connector

BSP	DIMENSIONS						PART NUMBER
	A	B	C	D	E	G	
3/8"	30	27.5	6.5	30	12		FG38-30
1/2"	30	27.5	6.5	30	12		FG12-30
3/4"	38	36	8.5	40	19		FG34-40

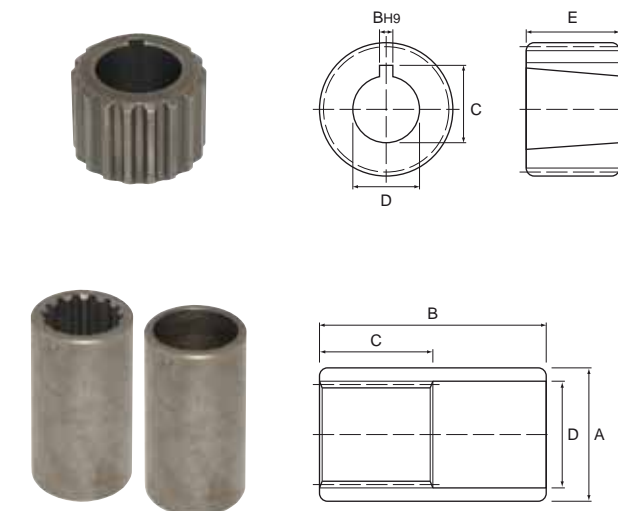

Group 2 Gear Pump Male Coupling

PROFILE DIN 5482	NO OF TEETH	DIMENSIONS				PART NUMBER
		B	C	D	E	
		mm	mm	mm	mm	
B25x22	14	3.17	16.5	14.3	22	2IS-14M
B28x25	15	3.17	15.8	14.3	22	2IS-15M

Group 2 Gear Pump Female Coupling

PROFILE DIN 5482	NO OF TEETH	DIMENSIONS				PART NUMBER
		A	B	C	D	
		mm	mm	mm	mm	
A25x22	14	32	60	30	25.5	2IS-14F
A28x25	15	34	60	30	28.5	2IS-15F